



TOWLE WHITNEY LLC



**TW3000S-210W-50 TRIPLEX
VARIABLE SPEED BOOSTER PUMP SYSTEM**



The *TW3000S-210W-50 Triplex Booster Pump System* is equipped with centrifugal pumps regulated by variable frequency drives that control the pump operation to maintain constant pressure regardless of varying demand or fluctuation in incoming pressure. This system will supply 210 GPM with a 50 PSI overboost.

System is built on a MODULAR frame for ease of transport and installation.

VFD drives will ALTERNATE lead pump every 24 hours of run time. 2nd and 3rd pumps will remain in standby until needed.

Lead-Free (Wetted) components:

- Pumps: Cast Iron or SS Option
- Relief valves: LF Brass
- Pressure Gauges: Stainless Steel
- Transducers: Stainless Steel
- Check valves: LF Brass
- Ball Valves: LF Brass
- Manifolds: Type L Copper
- Fittings: LF Brass or SS

* All lead-free brass shall contain <.25% Pb



*All parts shown included
Actual system components may vary
Some assembly required*

Performance curve for each pump

Technical Specifications:

- Pumps:** Walrus [12T-4K]
- Horse Power:** 3 HP per pump
- Controllers:** Yaskawa
- Flow Rate:** 210 GPM (70 GPM per pump)
- Boost:** 50 PSI Overboost
- Manifolds:** 3 inch
- Tank:** Flexcon H2P35 (33 Gallon)
- Frame Size:** 48" W x 54" H x 34" D
- Power Options:** Three independent circuits required
208-220V/1PH or
208-220V/3PH or
360-480V/3PH
Specify when ordering

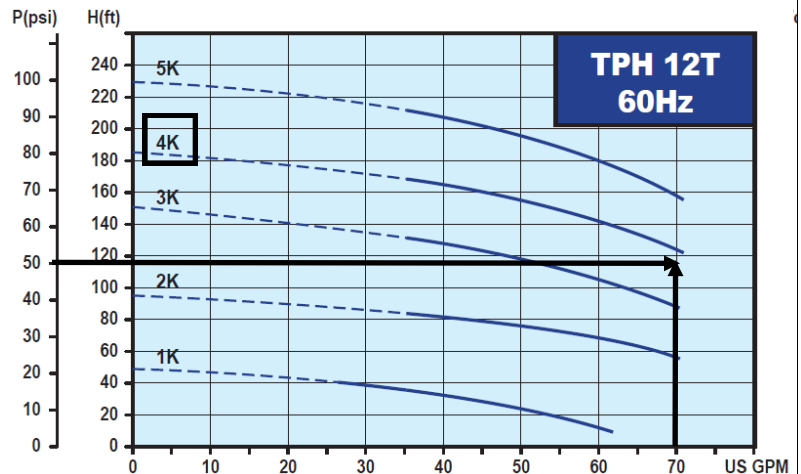

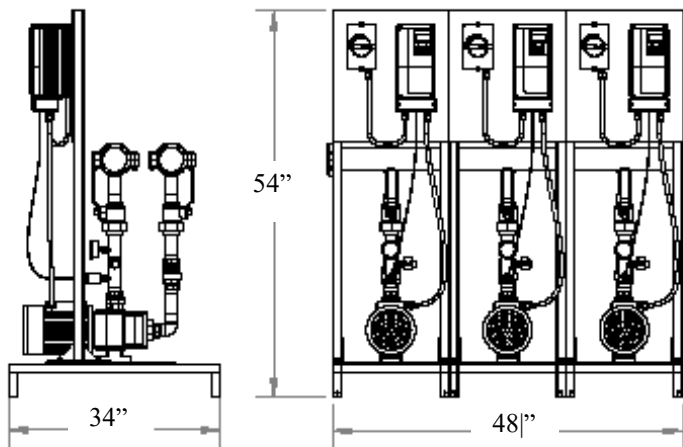
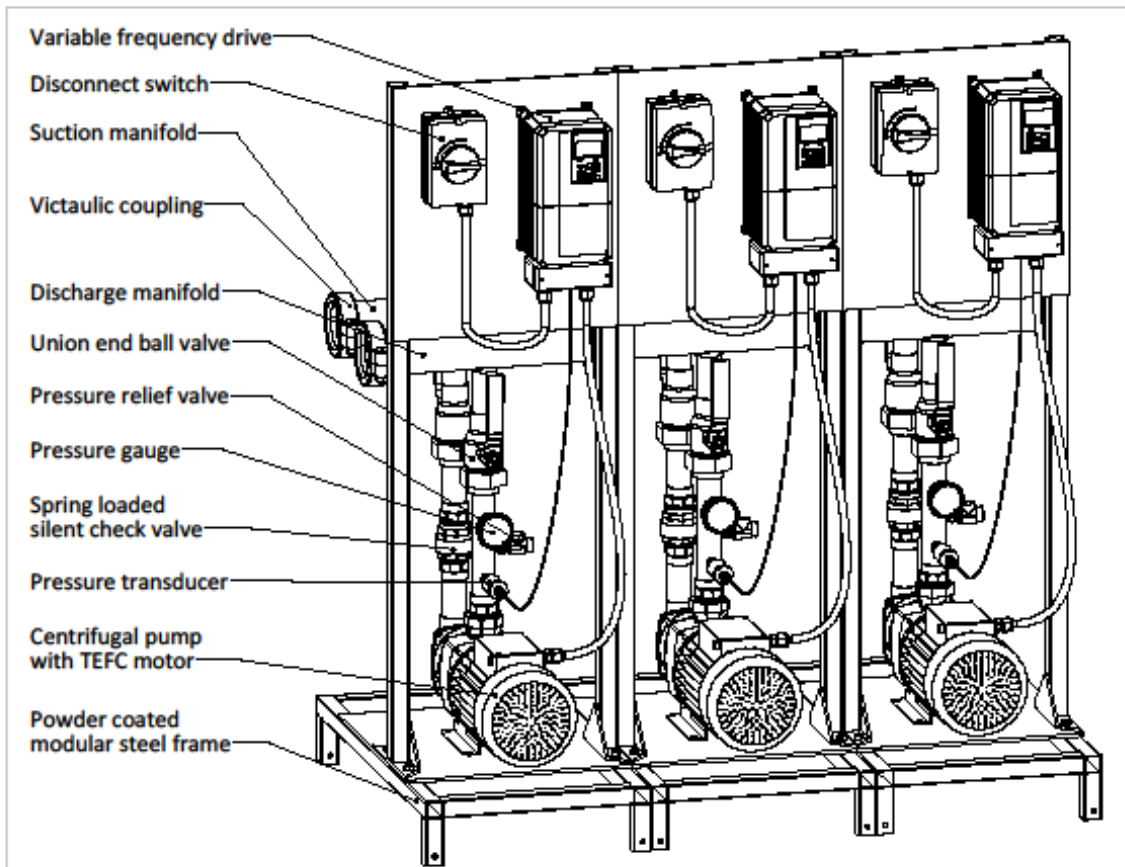

<p>PROPRIETARY AND CONFIDENTIAL THE INFORMATION CONTAINED IN THIS DRAWING IS THE SOLE PROPERTY OF TOWLE WHITNEY LLC. ANY REPRODUCTION IN PART OR AS A WHOLE WITHOUT THE WRITTEN PERMISSION OF TOWLE WHITNEY LLC IS PROHIBITED.</p>	<p>DIMENSIONS ARE SUBJECT TO CHANGE DO NOT USE FOR CONSTRUCTION UNLESS OTHERWISE SPECIFIED DIMENSIONS ARE IN INCHES</p>	NAME	DATE
		VID	12/2/14
DO NOT SCALE DRAWING		CHECKED:	COMMENTS:
		<p>TOWLE WHITNEY LLC Triplex Variable Booster System</p>	
SEE	DWG. NO.	REV.	
A	12022014A		
SCALE:1:20	WGGH:	SHEET 1 OF 1	

21 Londonderry Turnpike, Hooksett, NH 03106

Tel: 603-626-7371/1-800-807-9827 Fax: 603-626-7372

www.towle-whitney.com info@towle-whitney.com



GENERAL SPECIFICATIONS

Assembled Units:

- All “wetted surfaces” shall be lead free (<.25% Pb) in conformance with the 1/4/14 federal law
- Shall include a separate and independent variable frequency drive (VFD) for each pump with a pressure transducer, pressure gauge, and relief valve. Piping and frame shall not interfere with access to the controls
- Each pump shall include isolation valves on both the suction and discharge piping
- Each pump shall have a separate and independent disconnect box
- Shall be mounted on a modular frame for ease of transport and installation. The pump & drive wiring harness shall remain intact after frame is split apart (with the exception of “network wire”)

Variable frequency drive:

- Will ALTERNATE the lead pump every 24 hours (field adjustable) of run time. The remaining pump(s) shall be in standby
- Shall have lead/lag & alternation feature without an external control panel or PLC
- Shall have hands-off automatic (HOA) capability
- Rated to operate using specified power requirement. The drive efficiency shall be 98% or better
- Have UL approval with all factory installed options and preset values and/or last saved data values will remain available to the operator after power outage
- Shall have at least NEMA 1 rated conduit enclosure
- The program will protect the pumps against damaging hydraulic conditions such as:
 - Motor overload, Pump overflow surges, Loss of prime due to incoming water supply interruption, Hunting
 - Protection from overload through frequency/current optimization
 - Protection from hydraulic damage by restricting the pumps to operate beyond their published end of curve
- Shall have the ability to automatically restart after an over-current, over-voltage, under-voltage or loss of input signal
- Shall have an operator control panel [keypad] for customization of parameters
- Shall include a feature to upload/download parameters into an external device to be used with another drive or the same drive
- Shall have a removable non-volatile memory device
- Shall be capable of accepting individual analog inputs from transducer. All transducer inputs must be wired to the variable frequency drive for continuous scan and comparison function
- Ladder logic program shall utilize a proportional - integral - derivative control function
- Shall display the following values:
 - Pump running/standby, Pump speed in Hz, User adjustable parameters such as PID set points, Motor frequency, Motor current, Threshold set points for PID error, Min operating frequency, Troubleshooting and diagnostics of faults

Transducer:

- The transducer shall be rated for required system pressure and shall be 4-20 mA analog
- Separate transducers shall be supplied for each variable frequency drive to ensure redundancy

Centrifugal pump:

- Shall have a cast iron casing with 304 stainless steel impellers. (All Stainless Steel pumps are an available upgrade)
- Shall have a 316 stainless steel shaft sleeve. Mechanical seal shall be rated to withstand pressure of up to 142 PSI
- Motor shall be totally enclosed fan cooled (TEFC). and manufactured in compliance with CE, RoHS and CSA

Pneumatic expansion tank:

- Pneumatic expansion tank shall be rated for use with potable water with an operating pressure of a maximum 125 PSI
- Shall be pre-charged to a pressure of 10 PSI below system operating pressure for system to run properly

Manifolds, valves and fittings:

- Shall be sized appropriately to allow water velocity not exceeding 10 ft/sec, to minimize cavitation and turbulence
- All shut off valves shall be standard port ball valves and check valves shall be silent and spring-loaded
- Shall be dual end with roll grooved ends to plumb from left or right and supplied with one set of Victaulic caps and couplings.

Installation:

- Equipment shall be installed in accordance with applicable local building, electrical and plumbing codes
- Shall be installed indoors (unless otherwise specified) and protected from water spray



VARIABLE FREQUENCY DRIVE WARRANTY AND SPECIFICATIONS



Warranty: Provide VFD warranty, for one year from startup, not to exceed 18 months from the date of shipment. Warranty shall include parts, and labor allowance for repair hours.



Performance Features (Drive)

- Ratings:
 - 1 to 5 HP at 200-240 VAC 1-Ph.
 - 1 to 25 HP (ND) at 200-240 VAC 3-Ph.
 - 1 to 25 HP (ND) at 380-480 VAC 3-Ph.
- Overload Capacity: 120% for 60 sec. (Normal Duty)
- Control Methods: V/f Control, Open Loop Current Vector Control
- DC injection braking, ramp to stop
- Electronic reversing
- Adjustable accel/decel: 0.01 to 6000 seconds
- Controlled speed range: 40:1⁽¹⁾ 100:1⁽²⁾
- Speed Regulation:
 - ± 0.5 to 1% with slip compensation⁽¹⁾
 - ± 0.2%⁽²⁾
- Displacement power factor: 0.98
- Output frequency: 0 to 400 Hz
- Frequency resolution: 0.01 Hz with digital reference 0.06 / 60 Hz with analog reference
- Frequency accuracy: 0.01% with digital command 0.5% with analog command
- Volts / hertz ratio: infinitely adjustable pattern
- DC Injection braking: adjustable amplitude, duration, current limited
- Torque boost: full range, auto
- Power loss ride-thru: 0.5 sec.
- Speed search
- Auto restart
- 3 Critical frequency rejection settings
- Slip Compensation
- Energy Savings Function
- Enhanced PID with loss of feedback function

⁽¹⁾ V/f Mode

⁽²⁾ Open Loop Current Vector Mode

Design Features (Drive)

- Dual microprocessor logic
- Digital keypad operator, 5 digits
- LED status display
- Remote Mount Keypad Capability
- RJ-45 Style Digital Operator Connector
- 7 multifunction digital inputs
- 3 multifunction digital outputs
- Hardwire baseblock (EN954-1 Cat. 3)
- Programmable form C output contact for customer use: 1A at 250 VAC or 30 VDC
- 24 VDC control logic compatible with sourcing or sinking outputs (PNP or NPN)
- Carrier frequency: 15 kHz max; swing PWM
- 2 Remote speed references: 0-10 VDC (20 kohms) or isolated 4-20 mA (250 ohms)
- Signal follower: bias and gain
- 2 programmable open collector outputs
- Analog monitor output: 0-10 VDC proportional to output frequency or output current
- Approx. 400 parameters and monitors
- Digital pulse train input (33 kHz max.)
- Cooling fan controlled by drive run/stop
- RS-422/485 Modbus 115 kbps
- UL recognized electronic overload
- MTBF: 28 years
- NEMA 1 enclosure
- Side-by-Side mounting
- Maintenance monitors

Protective Features (Drive)

- Current limit, stall prevention during accel, decel, and run
- Motor and drive overload
- Over voltage prevention function
- Instantaneous over current
- Short circuit
- Under voltage
- Heatsink overheat
- Ground fault protection
- Over/under torque
- Short circuit current rating: 30kA rms sym.

Pump Control Features

- Operator keypad with intuitive pump language
- Hand-Off-Auto
- Programmable pump process set point
- Pump start level and start time
- Sleep protection
- Simplex, duplex and triplex control
- Automatic system restart
- No flow detection
- Low and high feedback set points
- Pre-charge low level control
- Thrust bearing control
- Automatic system stabilization
- Motor condensation pre-heat function

Pump Protective Features

- Dry well
- Air in system
- Blocked impeller
- Pump over cycling
- No flow protection
- Loss of prime
- Transducer loss
- Over torque

Pump Alarms and Messages

- Low feedback
- High feedback
- Low level
- Low water
- Pump over cycling
- No flow detection
- Loss of prime
- Pump fault
- Motor thermostat
- Pre-charge mode
- Thrust bearing active
- Start mode active
- Sleep mode active

21 Londonderry Turnpike, Hooksett, NH 03106

Tel: 603-626-7371/1-800-807-9827 Fax: 603-626-7372

www.towle-whitney.com ned@towle-whitney.com



MULTISTAGE CENTRIFUGAL PUMP

WALRUS®

MULTISTAGE CENTRIFUGAL PUMP

TPH2T/4T/8T/12T

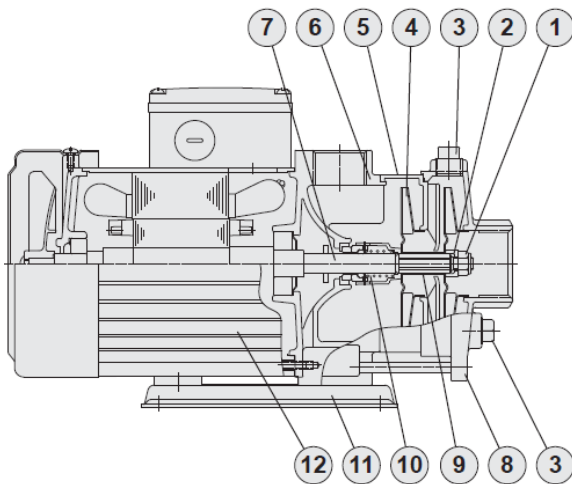

Motors:

- The pump is coupled with (TEFC) Totally Enclosed Fan Cooled, squirrel-cage motor.
- Nominal speed: 3500 rpm at 60Hz
- Protection class: IP54
- Insulation class: F

Pumps:

- Horizontal multi-stage centrifugal pump
- Non self-priming
- close coupled design
- Impellers mounted on extended motor shaft.

Materials

No.	Part name	Material		
		Standard	S series	N series
1	Lock Nut	SUS 316	SUS 316	SUS 316
2	Sleeve(Shaft End)	SUS 304	SUS 304	SUS 316
3	Water Plug	FC 20	SUS 304	SUS 316
4	Impeller	SUS 304	SUS 304	SUS 316
5	Intermediate Chamber	SUS 304	SUS 304	SUS 316
6	Pump Casing	FC 20	SUS 304	SUS 316
7	Shaft	SUS 304	SUS 304	SUS 316
8	Suction Chamber	FC 20	SUS 304	SUS 316
9	Sleeve	SUS 304	SUS 304	SUS 316
10	Mechanical Seal	Tungsten carbide + HNBR		
11	Mounted Base	Coating Steel	SUS 316	
12	Motor Shell	Aluminum alloy		

SUS 304 may be replaced by SUS316 depended on stock availability.

Operating Limits:

- Ambient temperature: Max. 104°F (40°C)
- Liquid temperature range: 32°F (0°C) to 194°F (90°C)
- Operating pressure: Max. 142 psi
- Inlet pressure: Max 85 psi

Suitable Liquids:

- Clean or other non-corrosive liquids





PNEUMATIC EXPANSION TANK SPECIFICATIONS



MATERIALS OF CONSTRUCTION

- **Tank:** 16 gauge cold rolled steel
- **Finish:** Appliance quality paint for indoor or outdoor installation
- **Water chambers:** Top chamber is 100% butyl rubber, lower water chamber is copolymer polypropylene
- **Connection:** Stainless Steel
- **Testing:** High pressure, seam weld, helium, final precharge check
- **Air valve:** Brass valve with o-ring seal
- **Warranty:** Five year

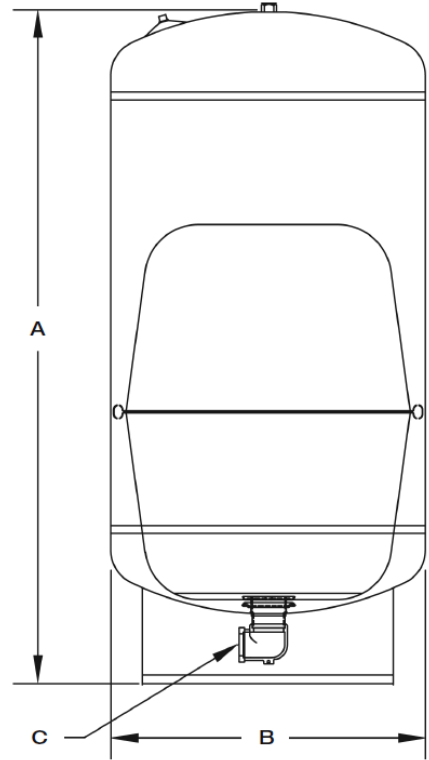

DIMENSIONS & CAPACITIES

Model	Total Tank Volume		A Height		B Diameter		C Connection	Total Weight	
	gal	liters	in	cm	in	cm		lbs	kilos
H2P 14	14	60	22	55.88	16	40.64	1" NPT	28.0	12.7
H2P 20	20	80	29	73.66	16	40.64	1" NPT	36.0	16.3
H2P 25	26	100	34.5	87.63	16	40.64	1" NPT	41.0	18.6
H2P 30	32	120	27.75	70.48	21	53.34	1 1/4" NPT	54.0	24.5
H2P 35	33.4	130	42.75	108.58	16	40.64	1 NPT	49.0	22.2
H2P 45	44	170	36.25	92.07	21	53.34	1 1/4" NPT	67.0	30.4
H2P 65	62	240	48	121.92	21	53.34	1 1/4" NPT	82.0	37.2
H2P 80	81	310	62	157.48	21	53.34	1 1/4" NPT	99.0	44.9
H2P 85	85	325	44.5	113.03	26	66.04	1 1/4" NPT	121.0	54.9
H2P 120	119	450	59.75	150.49	26	66.04	1 1/4" NPT	153.0	69.5

Maximum working pressure 125 psig. Maximum working temperature, internal & external 140° F. Tank pre-charge 38 psig.

21 Londonderry Turnpike, Hooksett, NH 03106

Tel: 603-626-7371/1-800-807-9827 Fax: 603-626-7372

www.towle-whitney.com info@towle-whitney.com



Booster Pump Systems

Three Year Limited Warranty

This warranty applies to booster pump systems built by Towle Whitney LLC, and shall:

- Exist 36 months from the date of shipment.
- Be in effect only after installation photographs are received by Towle Whitney LLC.

Towle Whitney LLC liability under this warranty shall be limited to the repair or replacement of any part or parts found to be defective (material or workmanship) within the warranty period. Towle Whitney LLC shall determine whether the part needs to be returned, or field scrapped. The warranty excludes:

- Transducer and pump seals.
- Debris in water causing internal pump damage.
- Any water damage or consequential damage.
- Systems not installed in accordance with Installation and Maintenance Instructions.
- Labor, transportation, and related costs incurred by the customer.
- Misuse, negligence, inappropriate chemicals or additives in water.
- Inadequate protection from freezing.
- Lightning, high voltage spikes, accidents, floods, or acts of God.
- Re-Installation costs of repaired or replacement equipment.
- Re-Imbursement for the loss caused by interruption of service.

This warranty applies to all states and territories of the United States and Canada only. There are no express or implied warranties, including merchantability or fitness for a particular purpose, which extend beyond those warranties described or referred to above.

Some jurisdictions do not allow the exclusion or limitation of incidental or consequential damages and some jurisdictions do not allow limit actions on how long implied warranties may last. Therefore, the above limitations or exclusions may not apply. This warranty gives you specific legal rights and you may also have other rights which vary from jurisdiction to jurisdiction.